



STEMOR

Jan Trzaska Sp. K.

ul. Władysława IV – 1, 70-651 Szczecin / POLAND

tel/fax. +48 91-8101258

www.stemor.eu info@stemor.eu



TE/248/883995/15



ADAP 211.0.0016
PHEN ISO 9001:2015



26

Data:
Miejsce:

14/04/2021
Szczecin

Emergency telegraph Type: ST-ATM-1.A

1. Description.

ST-ATM-1.A Emergency telegraph is fully electronic system that allows to transfer engine order between bridge and engine room with only two communication wires. ST-ATM-1.A fully comply SOLAS requirements.

Unit is intended for panel flush mount in 122mm x 122 mm rectangular hole. Front panel is made from UV painted polycarbonate reinforced with 2mm aluminum frame. Bottom chassis is made from ABS plastic. Cable connectors are located on back of device.

System operate with two identical units. Unit type is set by dip switch on back of device. Bridge unit, (master) has additional isolated VDR communication and unlocked dimmer. Units are design for 24V DC power supply. They can operate safely in range from 7 to 40V but below 16V visual and audio indications are compromised. Fault relay and indication are enabled when any of unit has power failure, or does not receive any correct internal communication frame.

Communication inside system is fully isolated, that allow to power units from different sources. RS485 with 9800bps is used to provide high resistance to external interference, all communication lines are surge protected.

2. Operation Principle.

Master unit periodically (100-250ms) broadcast self-status to slave unit, slave unit decode and send back response to master. In communication frame devices send own knob position, failure and alarm status. Each unit compare self and received knob position. When positions does not match device will go into alarm mode. Knob position of remote unit will flash red 100% brightens, alarm relay will be turn on, and sound alarm (if enabled) will sound.

Each unit check local power voltage, when voltage is out of range (less than 17V and more than 32V) fault will be enabled. When local unit doesn't receive any communication from remote unit after 2s timeout fault will be enabled. Fault is indicated by blinking (dimmer switch off) central tringle (just over position knob) and audible notification. Fault can be confirmed by any knob movement.



Figure 1. Device front panel



STEMOR

Jan Trzaska Sp. K.

ul. Władysława IV – 1, 70-651 Szczecin / POLAND

tel/fax. +48 91-8101258

www.stemor.eu info@stemor.eu



TE/248/883995/15



ADAP 211 0 0016
PH EN ISO 9001:2015



Data:
Miejsce:

14/04/2021
Szczecin

Master unit detect local and remote knob position, and if position is changed from previous state, unit will send message to VDR with current position. Master unit will send to VDR any detected fault condition, confirmation and clear status.

3. VDR communication sentence.

Standard NMEA 0183, RS422/485, 4800bps, 8bit, no parity check, 1 stop bit, no handshake

\$ ERTXT, EMERGENCY TELEGRAPH, XXXX, YYYY*hh<CR><LF>

\$ERTXT – Engine room monitoring system text message,

XXXX – text string with message type (see table 1)

YYYY – text string with order type (see table 2)

hh – checksum (“exclusive or” for all chars between \$ and * in hex)

VDR message type (XXXX)	Description
BRIDGE	Message refers to master unit (bridge)
ENGINE ROOM	Message refers to slave unit (engine room)
BRIDGE UNIT POWER FAILURE	Master unit power is out of safety range
INTERNAL COMMUNICATION FAILURE	Master unit cannot communicate with slave
ENGINE ROOM UNIT POWER FAILURE	Slave unit power is out of safety range
ENGINE ORDER NO ACK	Devices has different knob positions
SYSTEM POWER UP	Message send one time when power is connected
FAILURE CONFIRMED	Failure confirmed by operator
BRIDGE UNIT FAILURE CLEARED	Bridge unit power is out of safety range
E.R. UNIT POWER FAILURE CLEARED	Engine room return to safety range
INTERNAL COMMUNICATION FAILURE CLEARED	Communication between master and slave is restored

Table 1. VDR message type

VDR order type (YYYY)	Description
STANDBY	Order standby
[AH] DEAD SLOW	Order ahead dead slow
[AH] SLOW	Order ahead slow
[AH] HALF	Order ahead half
[AH] FULL	Order ahead full
[AS] FULL	Order astern full
[AS] HALF	Order astern half
[AS] SLOW	Order astern slow
[AS] DEAD SLOW	Order astern dead slow
END WITH ENIGNE	Order end with engine

Table 2. VDR order type



STEMOR

Jan Trzaska Sp. K.

ul. Władysława IV – 1, 70-651 Szczecin / POLAND

tel/fax. +48 91-8101258

www.stemor.eu info@stemor.eu



TE/248/883995/15



ADAP 2110:2018
PKN EN ISO 9001:2015



Data:
Miejsce:

14/04/2021
Szczecin

4. Technical specification.

Mechanical specification:

Height: 50mm
Length: 144mm
Width: 144mm
Mount: Flush mount, 122x122mm rectangular hole, screw 132x132mm
Ingress protection: Front IP42, back IP20

Electrical:

Supply voltage: 24V DC (17V-34VDC) protected against reversed polarity
Maximal current: 300mA
Internal protection: 500mA, resettable fuse
Dimmer: 2%-100% (32 stages)

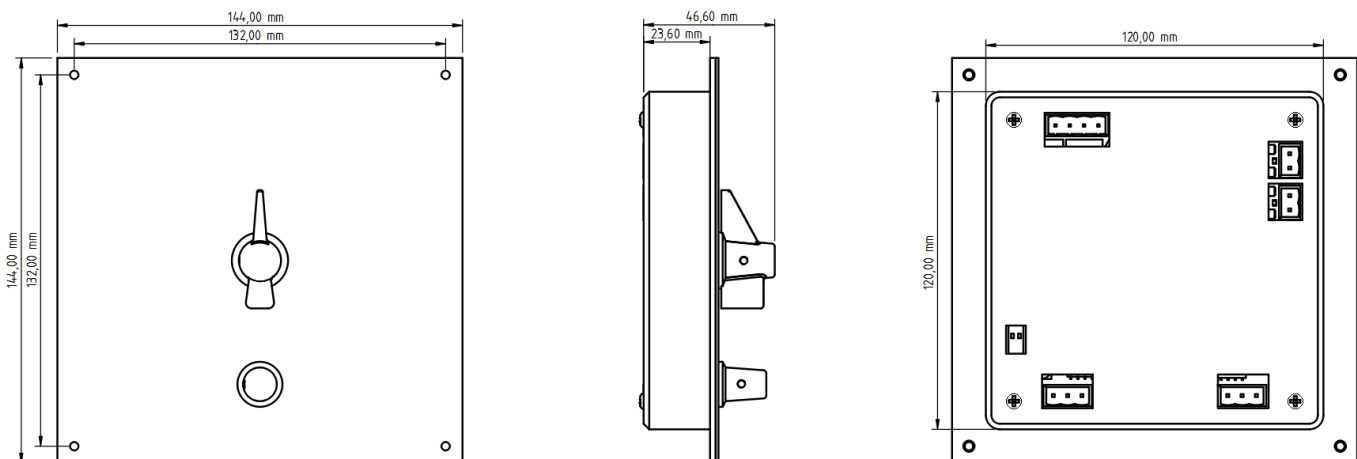

Figure 2: Mechanical dimensions

Dip Switch:

- 1- Buzzer ON/OFF
- 2- Master / Slave



STEMOR

Jan Trzaska Sp. K.

ul. Władysława IV – 1, 70-651 Szczecin / POLAND

tel/fax. +48 91-8101258

www.stemor.eu info@stemor.eu



TE/248/883995/15



ADAP 2110.0016
PKN ISO 9001:2015



Data:
Miejsce:

14/04/2021
Szczecin

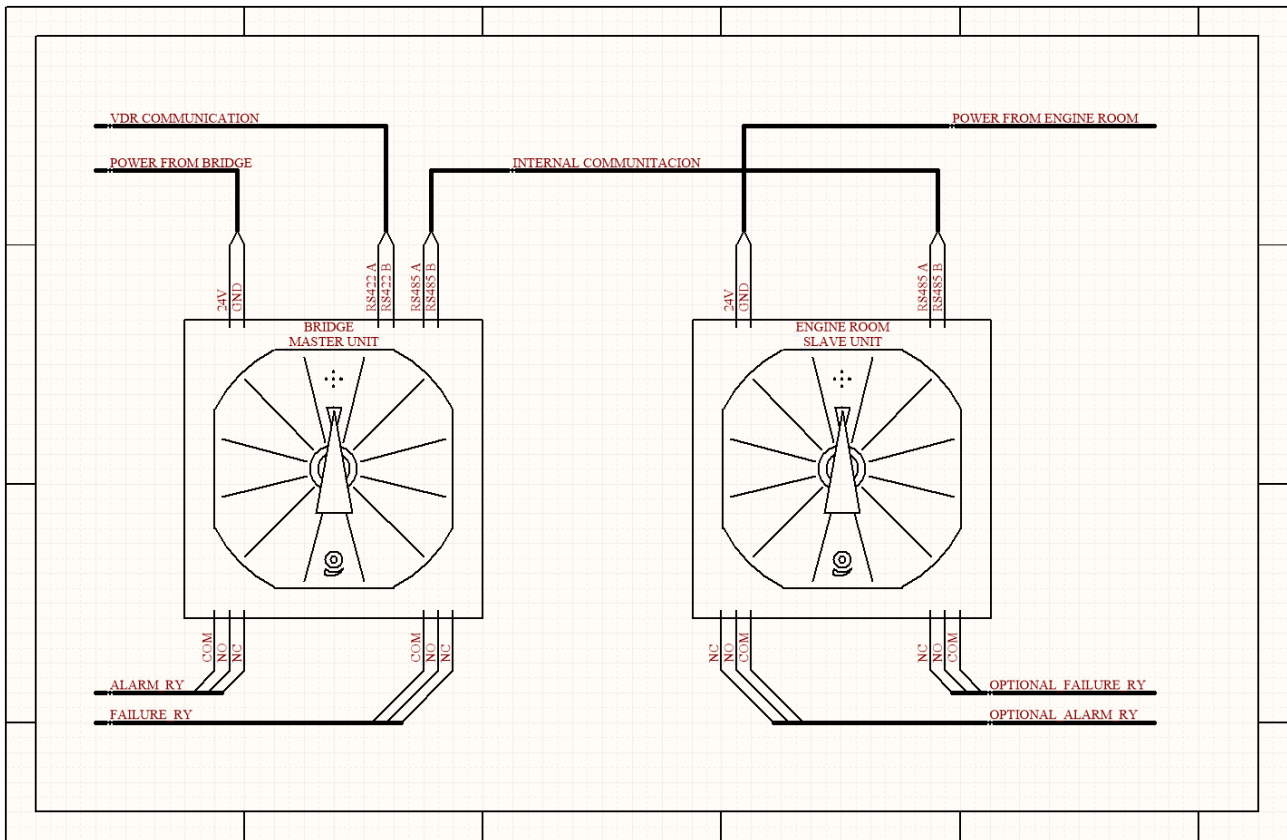

Figure 3: Emergency telegraph system electrical connection.

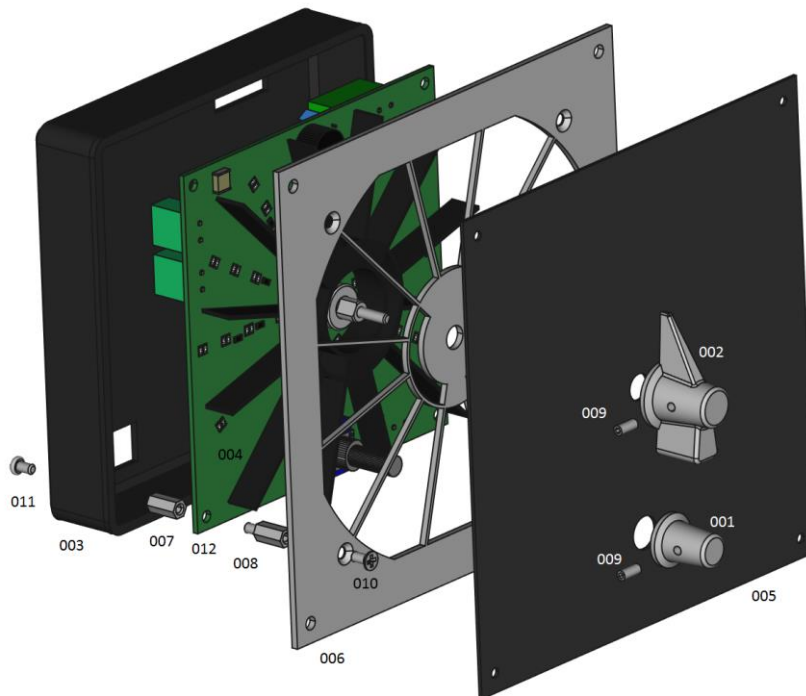

Figure 4 Exploded view